

CARBURETOR TUNING

Calibration Chart (for FCR, CR,)
PWK, PJ, PE)

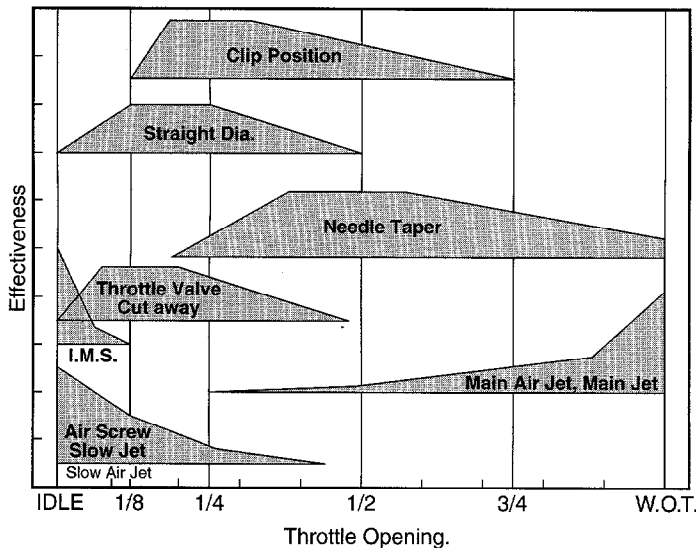

Float Height

FCR	CR	PWK	
ALL	ALL	28	35-39
9mm	14mm	19mm	16mm

PJ	PWM	PE		
ALL	38	24-38	30-34	36-38
16mm	6.5mm	14mm	20mm	22.5mm

NOTE: (See Jetting instruction #1) for correct procedure.

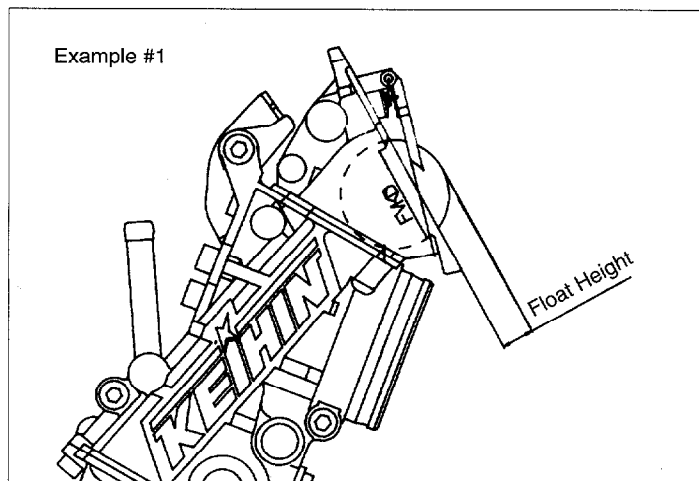

NOTE: If further information is needed, please contact your Keihin carburetor dealer.

Jetting Your Slide Valve Carburetors

All Keihin carburetors are pre-jetted for bolt-on operation. Carburetors are jetted using stock motorcycles and watercrafts. Any major engine modifications like higher compression pistons and racing exhaust systems may require minor jetting adjustments. The following is a guideline for jetting Keihin carburetors. Perform the jetting in the order given below.

1) CORRECT FLOAT HEIGHT

Before changing any jetting parts, check the carburetor floats for correct height. Measure the height from the bottom of the float to the carburetor-body gasket surface. Correct height can be found on the chart. When checking the float height, the float should be resting, but not depressing, the spring-loaded float valve pin. This can be done by tilting the carburetor until the float tab just makes contact with the valve pin. If adjustment is needed, bend the metal tab on the float arm until correct height is obtained.—see example #1

2) IDLE

Set idle speed to proper r.p.m. by adjusting the IDLE SPEED SCREW. Turn the IDLE MIXTURE SCREW or the AIR SCREW to achieve highest speed and best response. The IDLE MIXTURE SCREW (FCR) controls fuel delivery to the idle port and the SCREW is located on the engine side of the carburetor slide. Turning the IDLE MIXTURE SCREW out will make idle and off-idle richer. Turning IDLE MIXTURE SCREW (CR, PWK, PJ, PE) controls the amount of air to the IDLE and SLOW CIRCUIT. This SCREW is located on the air cleaner side of the throttle slide and turning the SCREW out will lean the mixture and turning the SCREW in (clockwise) will richen the mixture.

3) OFF IDLE TO 1/4 THROTTLE

The SLOW JET and SLOW AIR JET are most effective in this range. When you want a richer mixture in this range, use a larger SLOW JET or a smaller SLOW AIR JET. The opposite holds true for a leaner mixture.

Jet Needle Changes

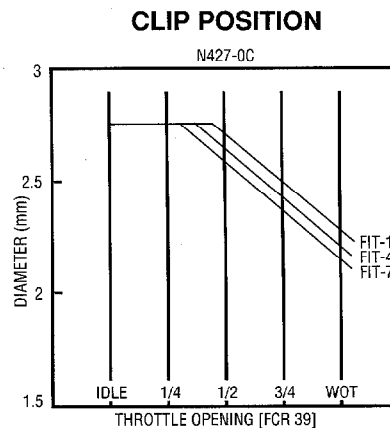
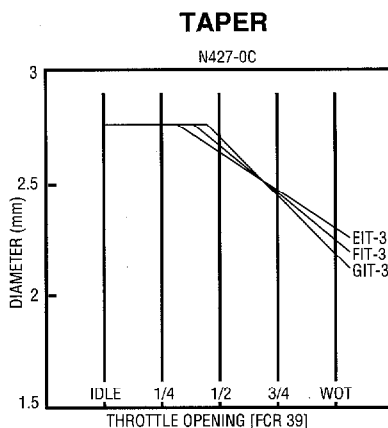
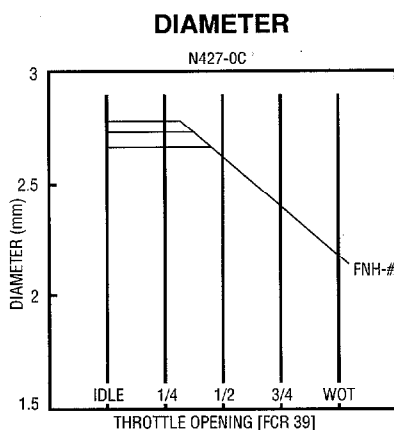

4) 1/4 TO 3/4 THROTTLE

The JET NEEDLE is the most effective component in the range. Changing the STRAIGHT DIAMETER (D) will change the calibration in the transition range from the SLOW circuit to the MAIN circuit (1/8 to 1/4) throttle. A smaller diameter will make this range richer and a larger diameter will lean this range. TAPER (A) changes are only made if there is a problem balancing the calibration between 1/4 and 3/4 throttle. If the mixture is rich at 1/4 throttle and lean at 3/4 throttle, a JET NEEDLE with a larger taper is needed. If mixture is lean at 1/4 throttle and rich at 3/4 throttle, change to smaller taper. If the calibration is lean from 1/4 to 3/4 throttle, raise the JET NEEDLE by lowering clip position, or use JET NEEDLE with shorter length (L1). If the calibration is rich, lower the JET NEEDLE with a longer (L1).

5) WIDE OPEN THROTTLE

Changing the MAIN JET affects this range. Select the size of MAIN JET which offers the best W.O.T. performance, then install one size larger MAIN JET for ideal engine durability.

6) ACCELERATOR PUMP (for FCR)

In normal applications, the ACCELERATOR PUMP should not require any adjustment. If a rich stumble occurs as the throttles are opened, the ACCELERATOR PUMP timing can be delayed by widening the gap on the ACCELERATOR PUMP linkage where it makes contact with the plastic lever. Reducing the gap will cause the ACCELERATOR PUMP to deliver fuel earlier.

7) THROTTLE VALVE CUT-AWAY (FOR CR, PWK, PJ, & PE)

THROTTLE VALVE CUT-AWAY will influence the calibration in the area of 1/8 to 1/4 throttle. What the CUT-AWAY does is change the air velocity over the MAIN NEEDLE JET which changes when the MAIN SYSTEM begins delivering fuel. If the transition is lean change the throttle valve to a valve which has less CUT-AWAY (lower number). If this range is rich use a throttle valve with more valve CUT-AWAY (higher number).

